

Bolt Through Kit

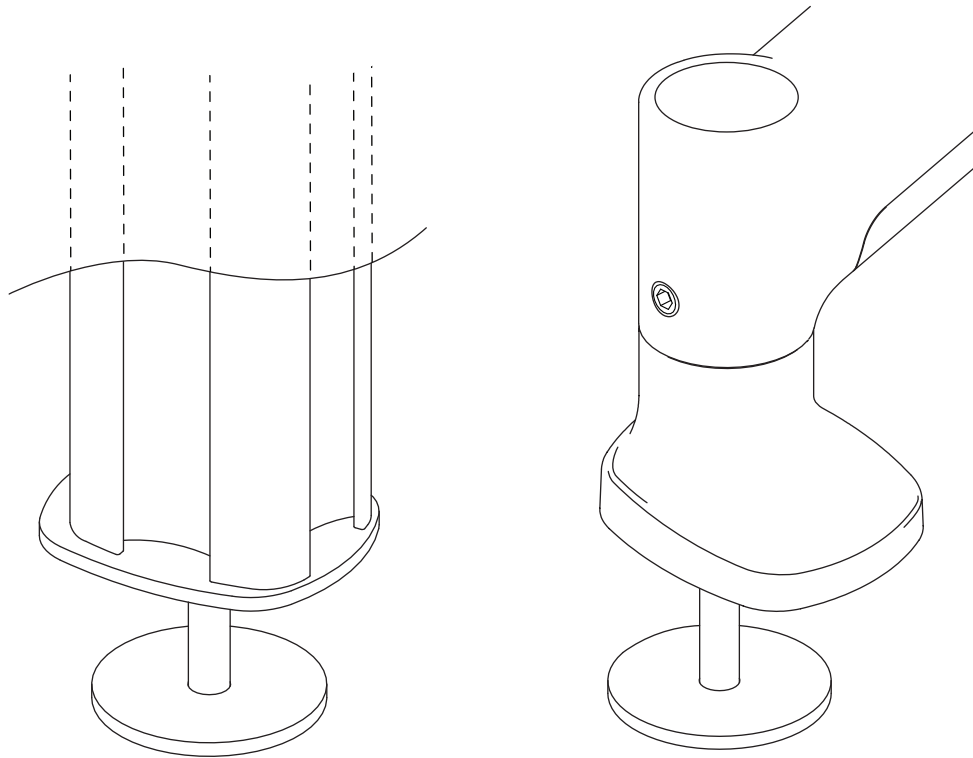

COMPONENT CHECKLIST

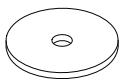

A
Bolt
through
washer
(x3)

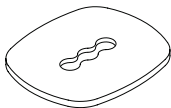

B
Bolt
through
plate
(x1)

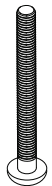

C
Bolt
M8x55mm
(x1)



D
Screw
M8x25mm
(x1)

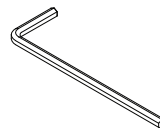

E
5mm
Hex Key
(x1)



REQUIRED TOOLS

- Power Drill
- 9mm (0.35") Drill Bit

IMPORTANT INFORMATION

- ! Please ensure this product is installed as per these installation instructions.
- ! This product is compatible with Atdec AWM Series products.
- ! The manufacturer accepts no responsibility for incorrect installation.
- ! Product must only be installed on a work surface capable of supporting the weight of all equipment being mounted.

1. Drill hole in work surface

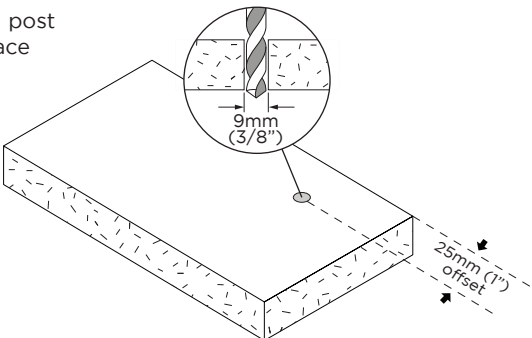
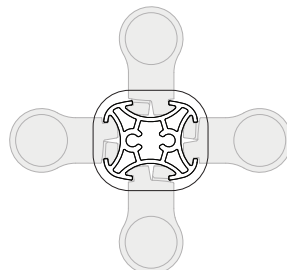
<p>1.1 Drill hole in desired post position on work surface</p> 	<p>1.2 Bolt through post mounting allows for arms to be installed into all four of the post channels</p> 
---	---

2. Configure bolt through

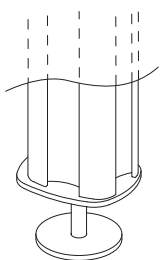
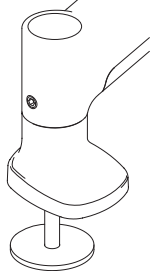
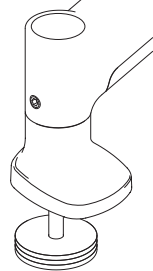
<p>2.1 Post - 1 x plate, 1 x washer</p>  <p>MIN THICKNESS 0mm (0") MAX THICKNESS 33mm (1 5/16")</p>	<p>2.2 Base - 1 x washer</p>  <p>MIN THICKNESS 20mm (13/16") MAX THICKNESS 34mm (1 5/16")</p>	<p>2.3 Base - 3 x washer</p>  <p>MIN THICKNESS 15mm (5/8") MAX THICKNESS 28mm (1 1/8")</p>
---	---	--

3. Post mount installation

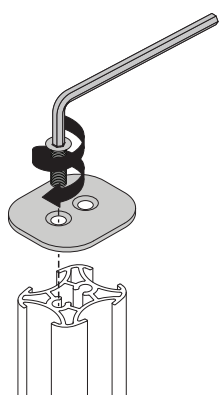
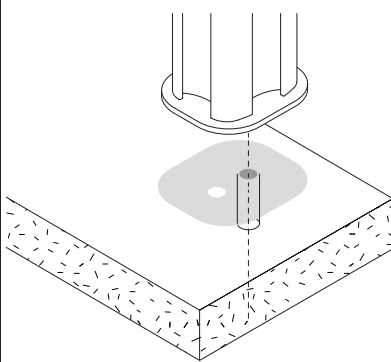
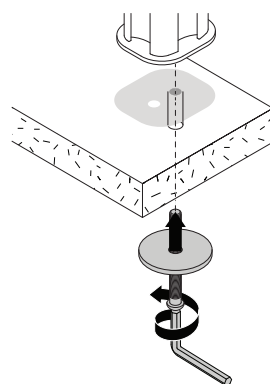
<p>3.1 Attach plate to post with M8x25 Screw</p> 	<p>3.2 Align rear hole with hole on desk</p> 	<p>3.3 Bolt post to work surface</p> 
---	---	---

4. Base mount installation

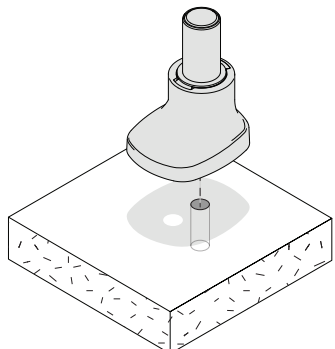
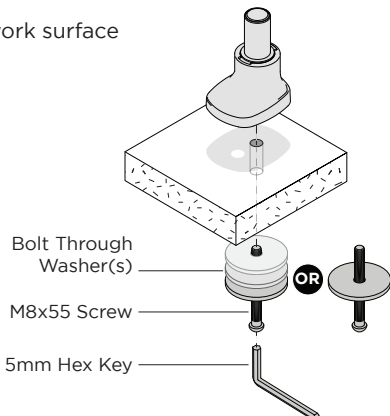
<p>4.1 Align rear hole with hole on desk</p> 	<p>4.2 Bolt base to work surface</p>  <p>Bolt Through Washer(s) M8x55 Screw 5mm Hex Key</p>
---	---