

Wall Channel

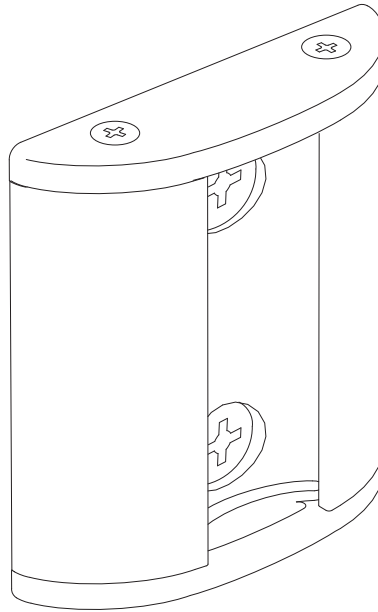

COMPONENT CHECKLIST

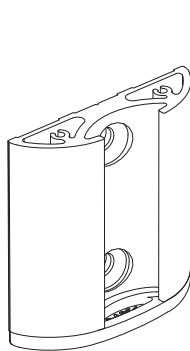

A
Wall channel
(x1)

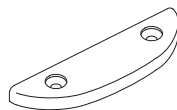

B
Top Cap
(x1)



C
Top Cap
Screws
(x2)

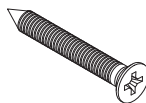

D
M6 x 50mm
Countersunk
Screw (x2)

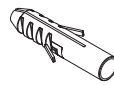

E
Nylon
Anchor (x2)



REQUIRED TOOLS

- Power drill
- Suitable drill bit
- Driver bit for selected wall fasteners
- Stud finder
- Spirit level

WEIGHT RANGE

0 - 12kg
(0 - 26.5lb)

Monitor weight should be within the weight range of all modular elements that make up the complete monitor mounting solution.

IMPORTANT INFORMATION

- ! **Please ensure this product is installed as per these installation instructions.**
- ! The manufacturer accepts no responsibility for incorrect installation.
- ! This product is not suitable for outdoor use.
- ! Do not use this product for mobile application.
- ! Wall Bracket only achieves maximum weight rating when appropriately fastened to a wall of adequate structural capacity.
- ! Professional installer to ensure adequate structural capacity of wall (including appropriate safety factor) to support total weight of all equipment being mounted.
- ! Drilling into electrical wires can cause death - use appropriate equipment and caution when drilling holes in walls to avoid electrical cables, water pipes and gas pipes. Do not drill into structures unless you have established it's safe to do so.
- ! This product is only compatible with AWM Series products, including: AWM-A13, AWM-A46, AWM-A71 and AWM-ADC.
- ! This product is **not** compatible with the AWM Heavy Duty Heads, including: AWM-LTH and AWM-LR.

1. Mount the Wall Bracket to the Wall

Using the Wall Channel as a template, mark the two fixing hole positions for drilling.

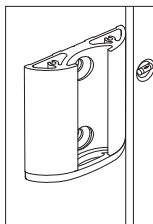
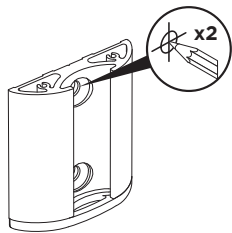

NOTE: Wall Channel must be level. Verify using a quality spirit level tool positioned along the side edge of the wall channel.

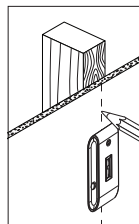

NOTE: On a Stud Wall, use a good quality Stud Finder to position mounting fasteners in the centre of studs.

OPTION 1: Masonry

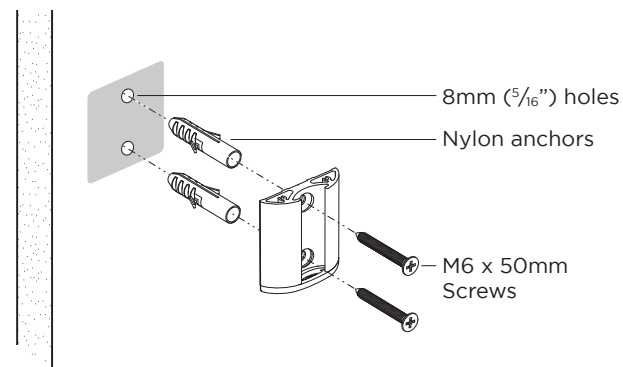

OPTION 2: Timber stud

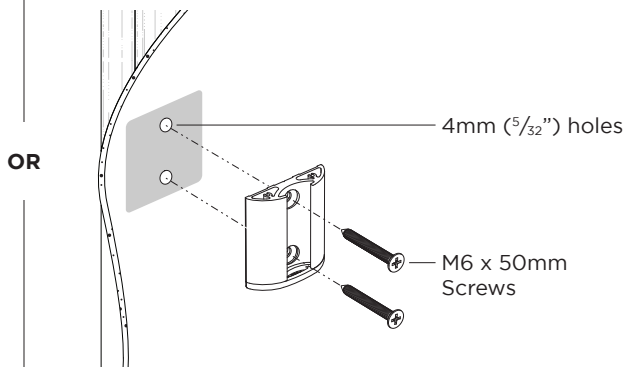

2. Fit channel clamp to Wall Channel

2.1 Ensure knob is undone.

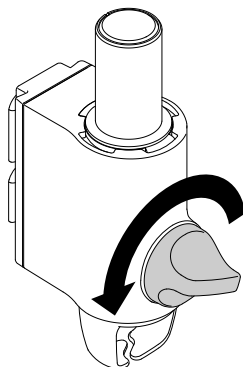

2.2 Slide clamp into channel.

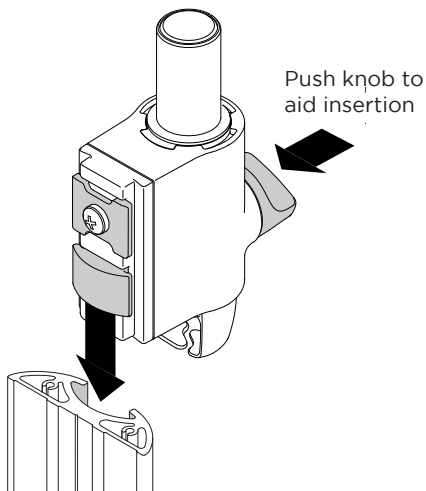

2.3 Hold clamp in desired position on post and turn knob to lock in place.

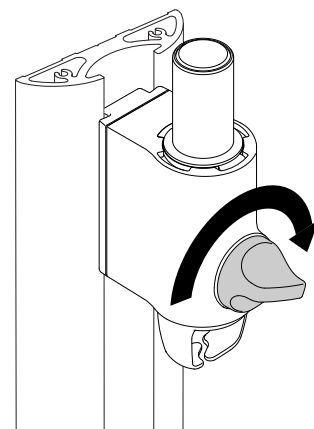

3. Fit Top Cap to Wall Channel

