

IMPORTANT INFORMATION

! IMPORTANT - Install Wall Mount as per Installation Instructions.

- ! Wall Mount supports Displays weighing up to 30kg (66lbs), with VESA hole configurations: 50x50mm, 75x75mm, 100x100mm, 200x100mm, 200x200mm.
- ! The Manufacturer accepts no responsibility for incorrect installation.

Component Checklist

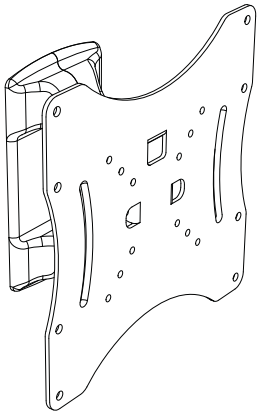

TH-2250-VTP
(fully assembled)

TOOLS REQUIRED:

- Power Drill
- Phillips Head Screw Driver
- 4mm ($\frac{3}{16}$ ") Drill Bit
- 8mm ($\frac{5}{16}$ ") Masonry Drill Bit

Hardware

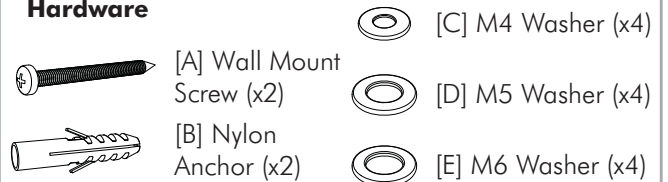

Mounting Fasteners



Step 1. Component Checklist

Check you have received all parts against the Component Checklist above.

Step 2. Remove the Wall Bracket Cover

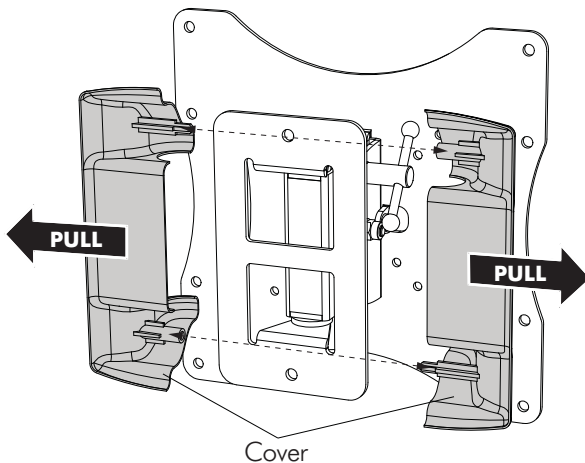

Step 3. Remove the Mounting Plate

Remove the two Locking Screws, on both left and right sides.

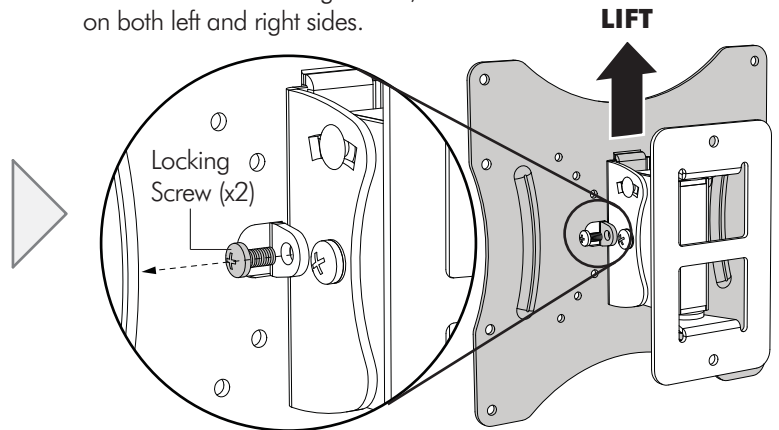

Step 4. Fix the Wall Bracket to the Wall

Using the Wall Plate as a drilling template, choose from one of the following Mounting options, **Timber Stud OR Masonry Wall**.

Timber Stud

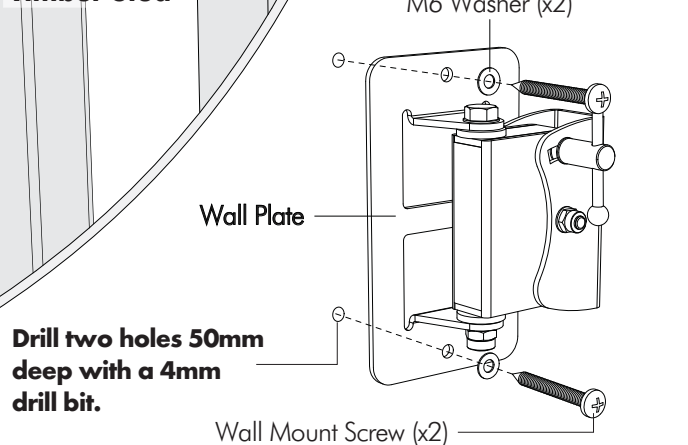

Masonry Wall

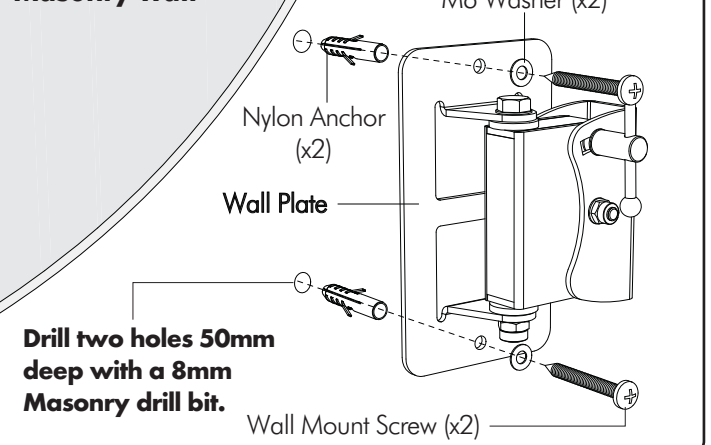

Step 5. Reinstall Wall Bracket Cover

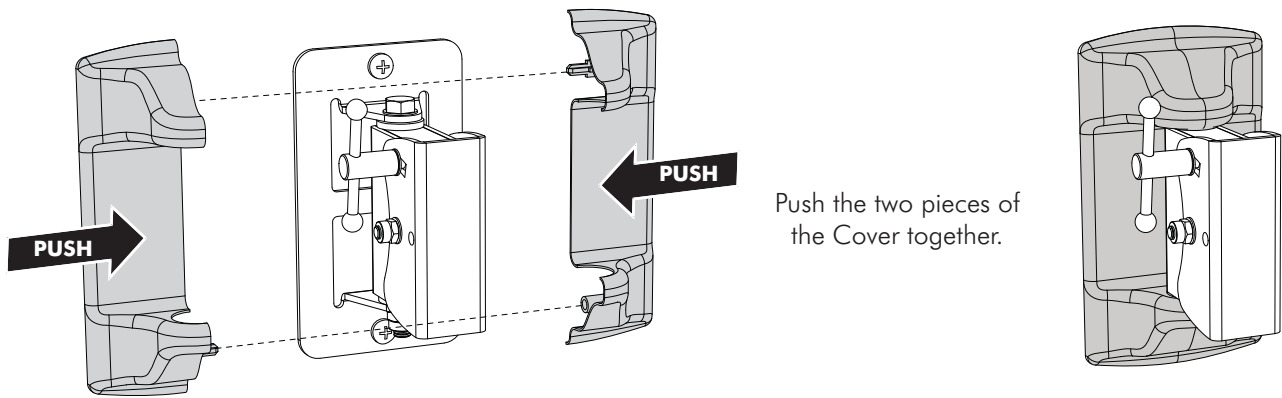

Step 6. Fasten the Mounting Plate to your Display

Choose appropriate Mounting Screws and Washers from the Hardware supplied to suit your Display.

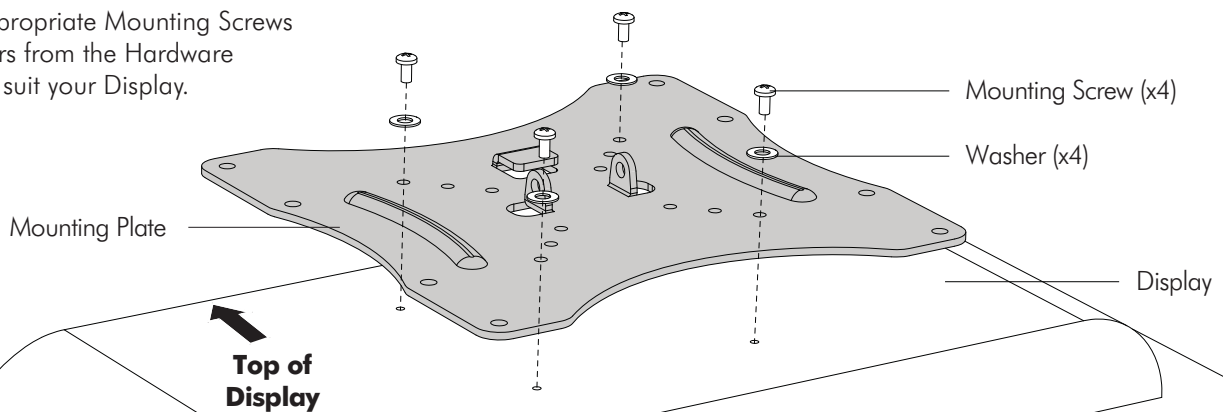

Step 7. Attach the Display to the Wall

(2 required)

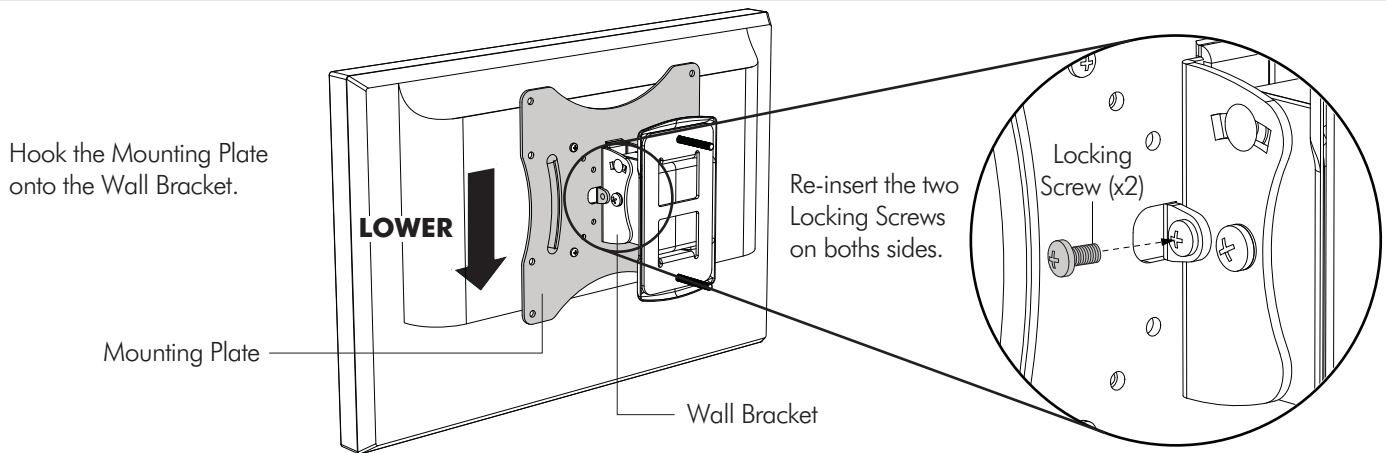

Step 8. Tilt Adjustment

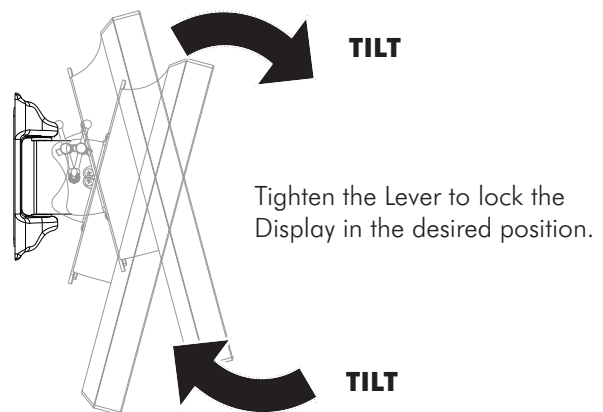
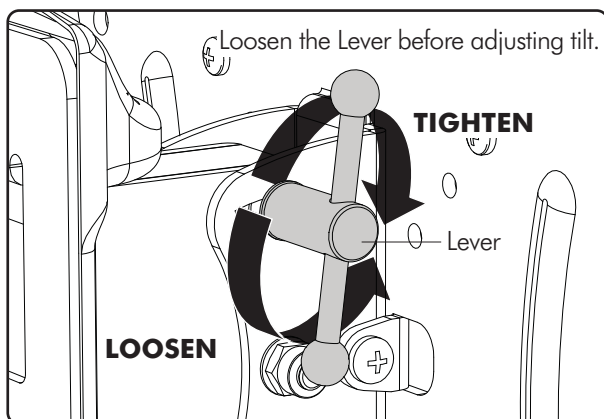

Installation Complete