

Component Checklist

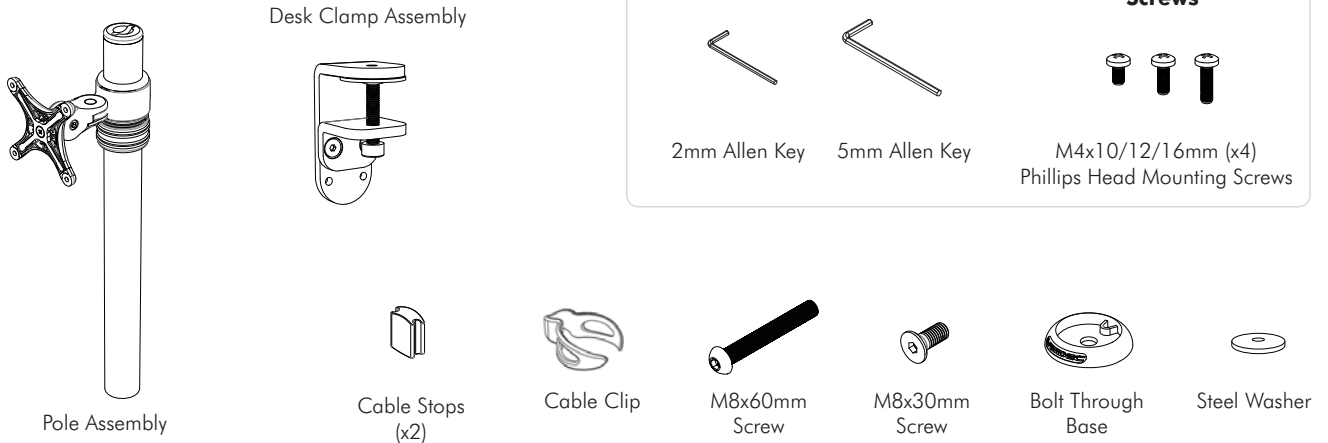

IMPORTANT INFORMATION:

- ! **IMPORTANT - Install Focus Micro Arm as per installation instruction.**
- ! This product supports a maximum load of 8kg (17.6lbs).
- ! The manufacturer accepts no responsibility for incorrect installation.

Step 1. Check Components

Check what you have received against the component checklist and hardware above.

Step 2. Mount Pole Assembly

Option 1: Bolt Through

It is recommended that the Pole Assembly be mounted towards the rear edge of the work surface.

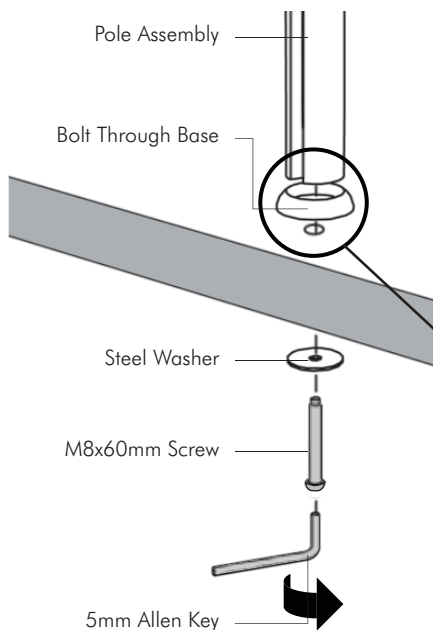

Option 2: Mount using Desk Clamp

2.1 Remove both the Pressure plate and M10 Desk Clamp Screw.

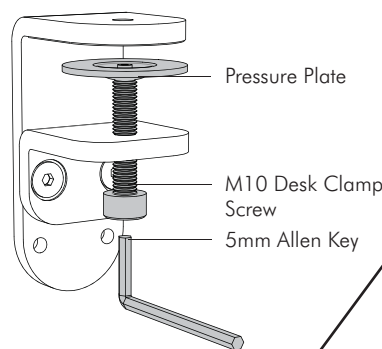

2.2 Fasten the Desk Clamp to the Bolt Through Base & Pole Assembly using the M8 x 30mm Screw and **Tighten Firmly.**

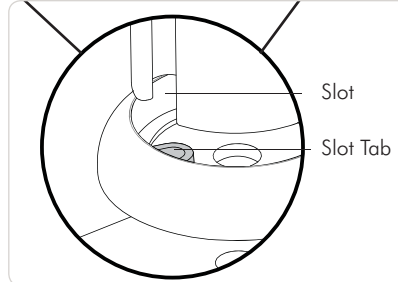
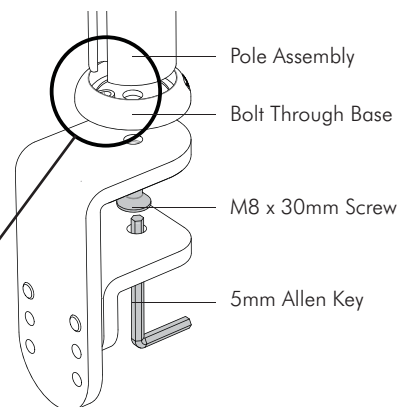

Note: Ensure that the Slot Tab in the Bolt Through Base fits snugly into the Slot on the Pole Assembly.

The logo on the Bolt Through Base must face the **front** of this assembly.

Step 2. Mount Pole Assembly (cont.)

2.3 The Desk Clamp bracket can be repositioned to suit different mounting surface thicknesses. The maximum mounting surface thicknesses supported are listed below from the Top to Middle and Bottom Screw Holes.

Top	0 - 32mm (default)	Top	29 - 69mm
Middle	7 - 47mm	Middle	43 - 84mm
Bottom	22 - 62mm	Bottom	59 - 99mm

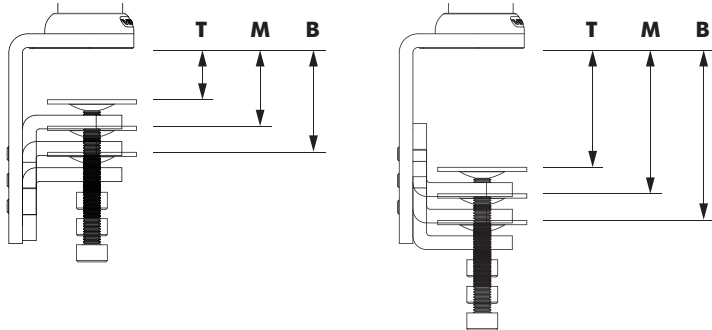

If you need to reposition the desk clamp bracket or you have no access to the rear of your table continue to **Step 2.4**. If you **DO NOT** need to reposition the desk clamp bracket and you have access to the rear of your table skip to **Step 2.7**.

2.4 Remove the M8 x 16mm Socket Head Countersunk Screws to release the Desk Clamp Bracket.

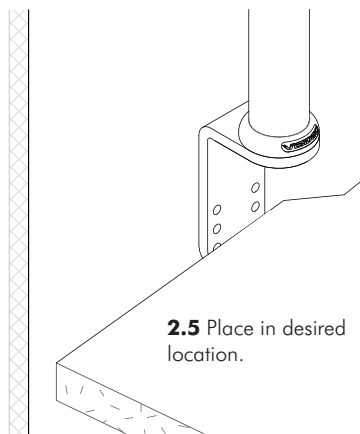
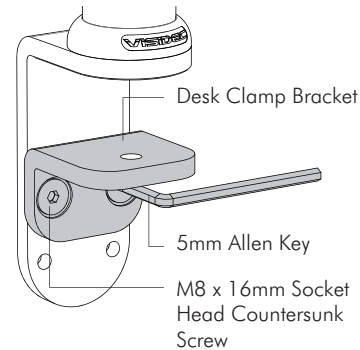

2.5 Place in desired location.

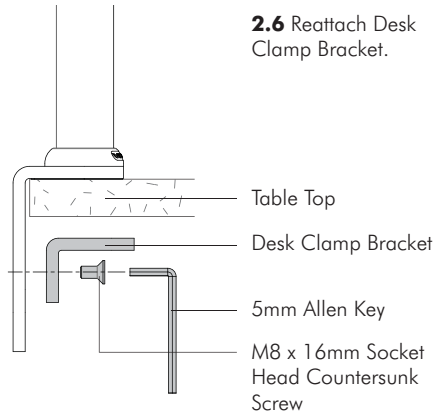

2.6 Reattach Desk Clamp Bracket.

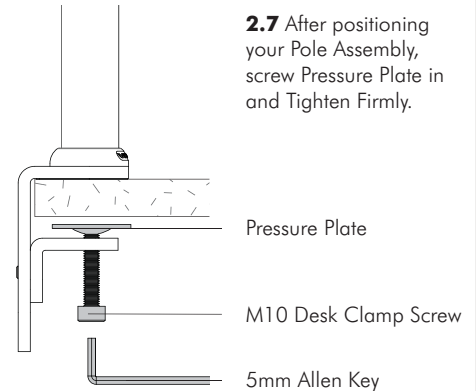

2.7 After positioning your Pole Assembly, screw Pressure Plate in and Tighten Firmly.

Step 3. Unlock/Lock Arm Rotation (Note: Focus Micro comes assembled in the "Locked" Position.)

Unlock

If you wish your Focus Micro Arm to have 360° rotation about the Pole you will need to unlock the arm's rotation.

Step 1: Unlock the arm by turning the Grub Screw anti-clockwise removing the Grub Screw completely.

Note: Store the Grub Screw in a safe place if you are to return the arm to the Locked position.

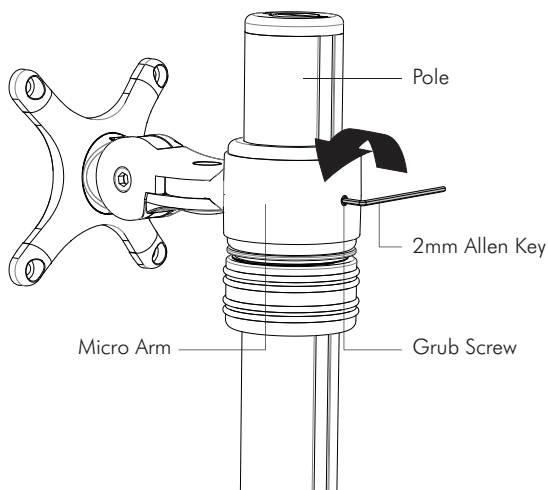

Lock

If you have unlocked your Focus Micro Arm, but wish to fix rotation around the Pole, you will need to lock the arm.

Step 1: Ensure the hole for the Grub Screw in the Micro Arm is lined up with the centre of the Slot in the Pole.

Step 2: Re-insert the Grub Screw previously removed. Turn the Grub Screw clockwise until it is tight. **Do not over-tighten.**

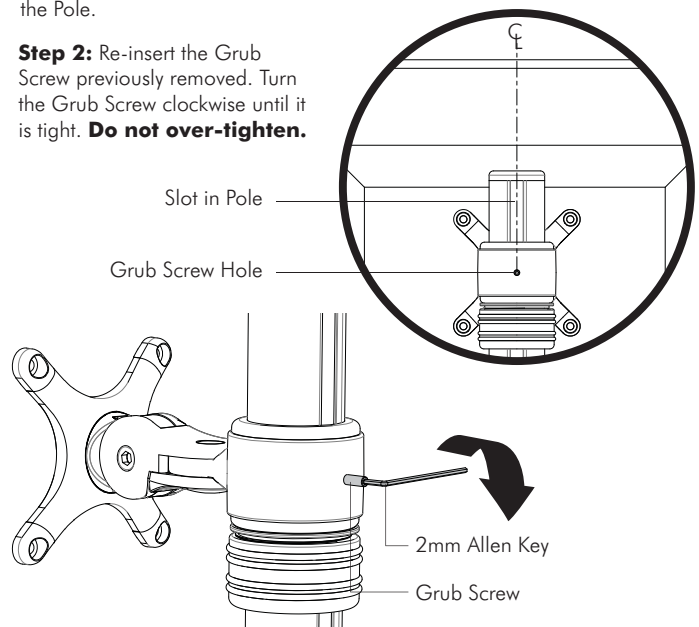

Step 4. Mount Display

Option 1: 75x75mm Hole Pattern

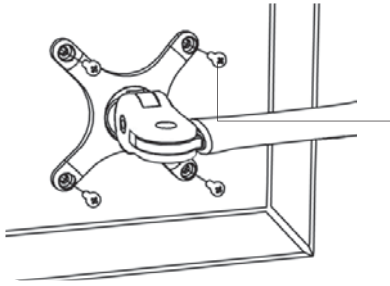

M4 Phillips Head
Mounting Screws

Option 2: 100x100mm Hole Pattern

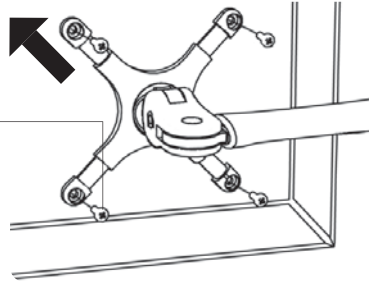

Note: Extend Arms to
achieve 100x100mm
hole pattern.

Step 5. Adjust Height

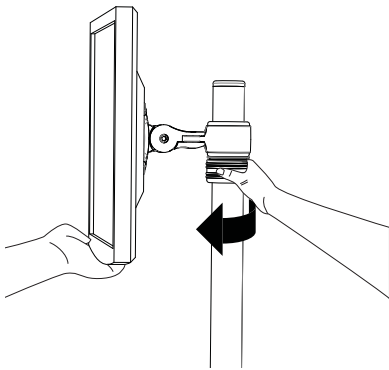

5.1 Unlock Handgrip ensuring both screen and arm assembly are supported.

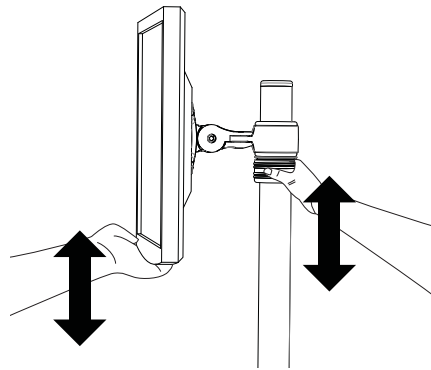

5.2 Lift/Lower Screen to the desired height.
Move both Screen and Arm assembly together.

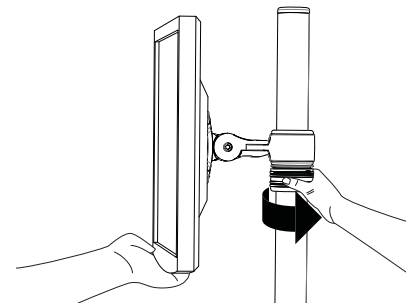

5.3 Lock Handgrip firmly.

Step 6. Cable Management

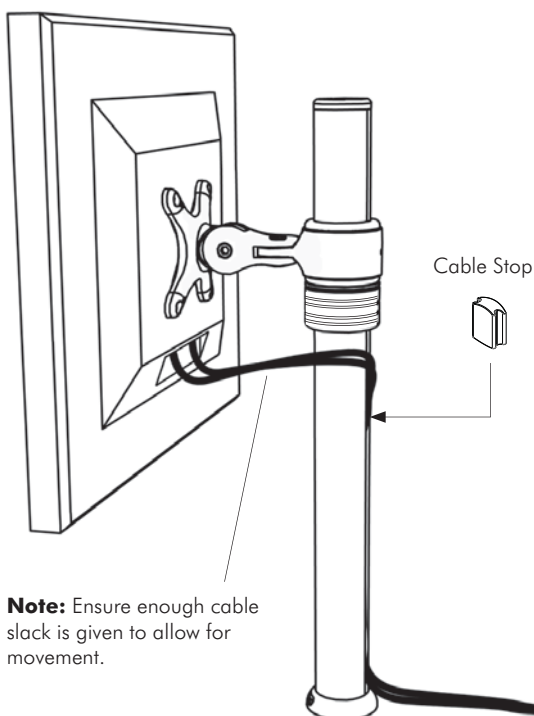

Note: Ensure enough cable
slack is given to allow for
movement.

6.1 After connecting cables, Cable Clips
and Cable Stops can be installed to further
manage cables.

Please See Over.

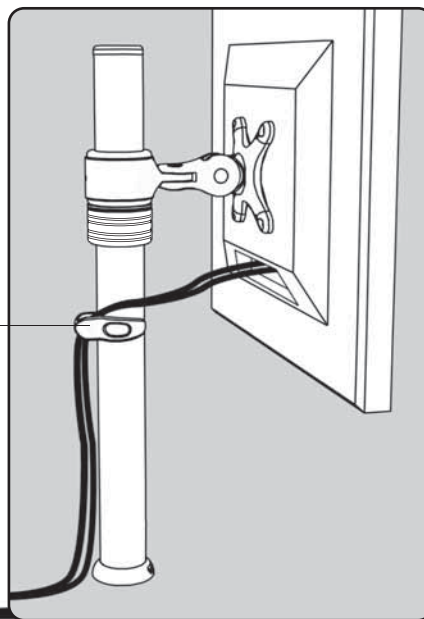

Note: If Focus Micro
is to be used in a multi
user environment, use
the supplied Cable Clip
to secure the display's
cables to the Pole.

Step 6.2. Insert Cable Stops

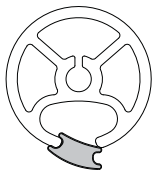

A. Insert Cable Stop on one edge of the Pole Slot.



B. Press down firmly onto the other edge of the Cable Stop and hold. This allows the rear profile to flex in place.



Step 8. Adjusting the Display Bracket

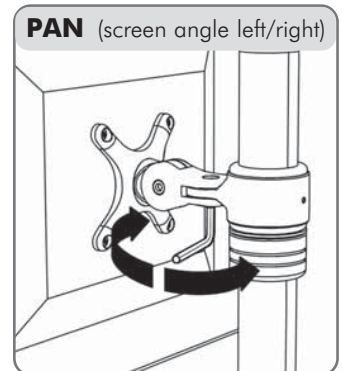
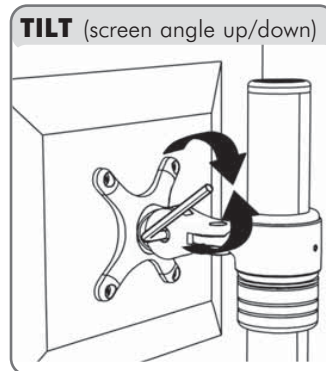
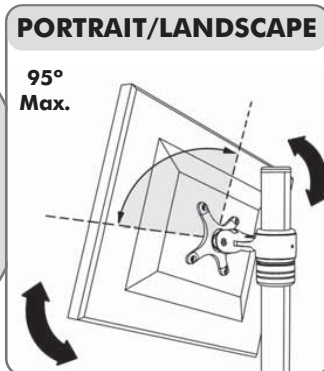
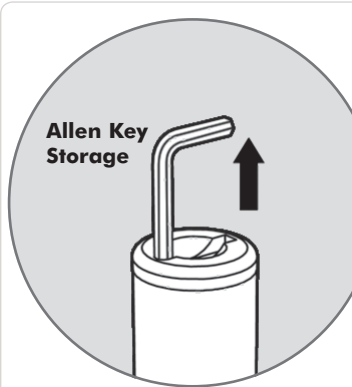

Ergonomic Guidelines

Many experts believe that the extended use of any computer screen has the potential to cause serious injury to your eyes, neck and back. This can be largely avoided by correctly positioning your display.

Viewing angle: Ergonomists recommend that the optimal position of your display should be slightly below eye level. When looking at the display's centre the user should have a downward visual angle of approximately 10°-20°.

Height: As a guide, the height (**h**) of your display should approximately be as follows:

- Tall Male (Max): 560mm (22")
- Short Male (Min): 368mm (14.5")
- Tall Female (Max): 520mm (20.5")
- Short Female (Min) 356mm (14")

Distance: For visual comfort, a viewing distance (**d**) between 500mm (20") to 750mm (29.5") is recommended.

Tilt Angle: Angular adjustments to reduce reflection on your monitor should range between 5° forward tilt to 15° backward tilt.

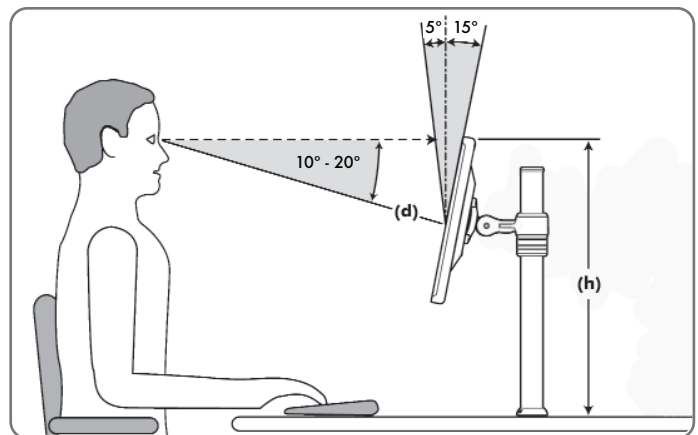

Installation Complete